

FEMALE END VIEW

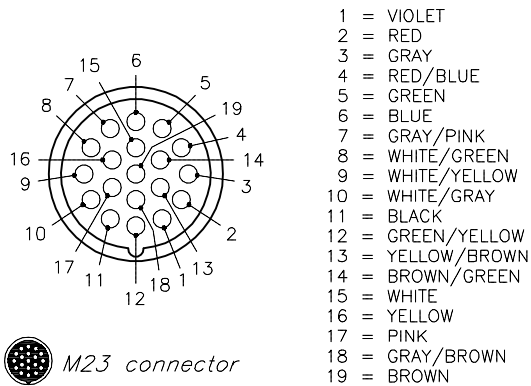

PANEL CUTOUT (TYPICAL)

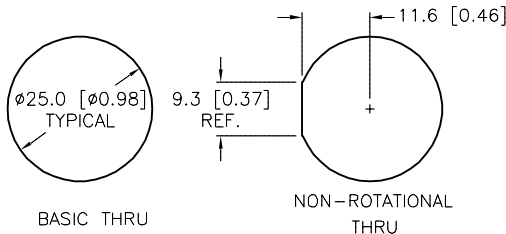

SPECIFICATIONS

CONTACT CARRIER MATERIAL	NYLON or PBT
CONTACT MATERIAL/PLATING	BRASS/GOLD
CONNECTOR HOUSING MATERIAL/PLATING	BRASS/NICKEL
O-RING/GASKET MATERIAL	RUBBER (NITRILE or FPM)
RATED CURRENT [A]	9.0 A (PINS 6,12,19), 2.0 A (ALL OTHERS)
RATED VOLTAGE [V]	150 V
OUTER JACKET MATERIAL/COLOR	TPU/YELLOW
CONDUCTOR INSULATION MATERIAL	PVC
NUMBER OF CONDUCTORS [AWG]	3x18 AWG/16x22 AWG
DRAIN/SHIELD	20 AWG/POLYESTER FOIL
TEMPERATURE RANGE	-40°C to +90°C (-40°F to +194°F)
PROTECTION CLASS	IEC IP67
MAXIMUM PANEL THICKNESS	6.5 [0.256]

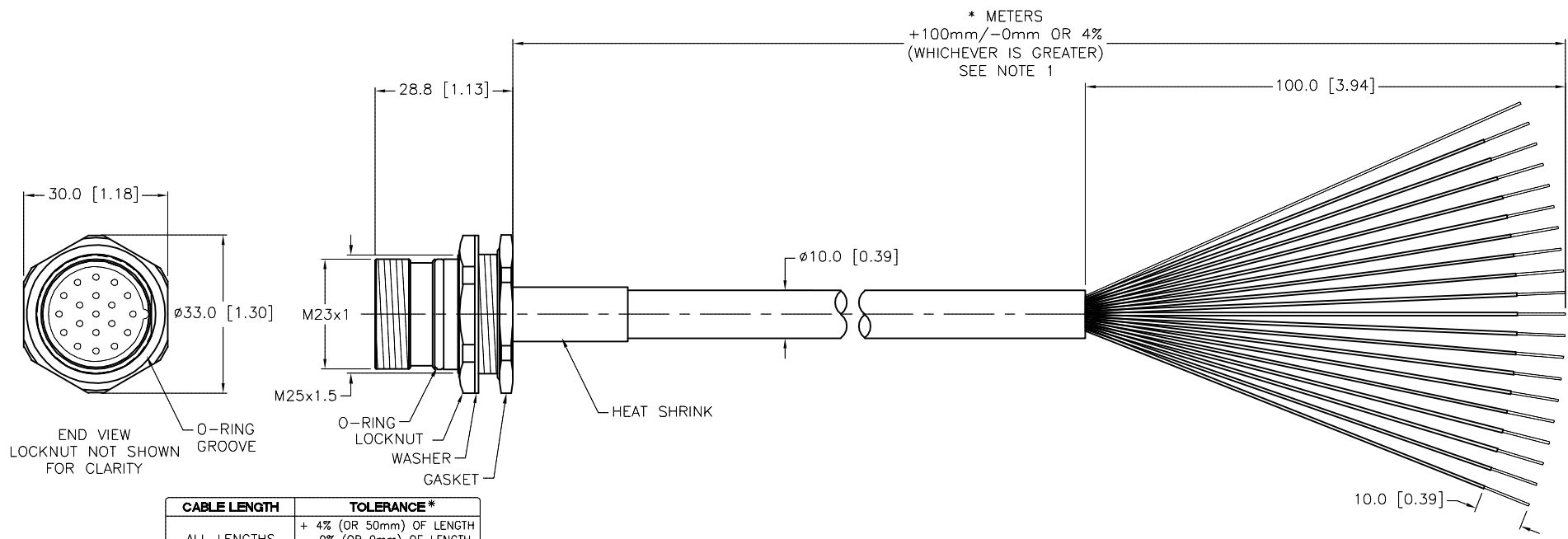

CABLE LENGTH	TOLERANCE*
ALL LENGTHS	+ 4% (OR 50mm) OF LENGTH - 0% (OR 0mm) OF LENGTH WHICHEVER IS GREATER
STRIP LENGTH	TOLERANCE*
0-7mm	±0.5mm
8-29mm	±1.0mm
30-49mm	±2.0mm
50-69mm	±3.0mm
70-100mm	±4.0mm
OVER 100mm	±5.0mm

*UNLESS OTHERWISE SPECIFIED

NOTES:

- "*" INDICATES CABLE LENGTH IN METERS. CONTACT TURCK TO ORDER SPECIFIC LENGTHS.
- "/S90" DESIGNATES THERMOPLASTIC POLYURETHANE (TPU) CABLE JACKET.
- "/S717" DESIGNATES RECEPTACLE ASSEMBLED WITH STANDARD CORDSET PVC CABLE.

SOURCE DRAWING - FOR REFERENCE ONLY

RELATED DOCUMENTS 1. 2. 3. 4.	3RD ANGLE PROJECTION 	THIS DRAWING IS CONFIDENTIAL AND THE PROPERTY OF TURCK INC. USE OF THIS DOCUMENT WITHOUT WRITTEN PERMISSION IS PROHIBITED.		3000 CAMPUS DRIVE MINNEAPOLIS, MN 55441 1-800-544-7769 (763) 553-7300 (763) 553-0708 fax www.turck.us			
		DRFT	RDS	DATE	05/11/09	DESCRIPTION	CKFD 19-19-*/S90/S717
MATERIAL	SEE SPECIFICATIONS	APVD	SCALE	1=1.3	IDENTIFICATION NO.	REV	F
FINISH	SEE SPECIFICATIONS	UNIT OF MEASUREMENT		MILLIMETER [INCH]		DO NOT SCALE THIS DRAWING	
CONTACT TURCK FOR MORE INFORMATION		FILE: 777015401		SHEET 1 OF 1			

F	UPDATE GASKET MATERIAL	NF	11/20/19	75416
REV	DESCRIPTION	BY	DATE	ECO NO.